

In-Class Assignment

State if the triangles in each pair are similar. If so, state how you know they are similar and complete the similarity statement.

1)

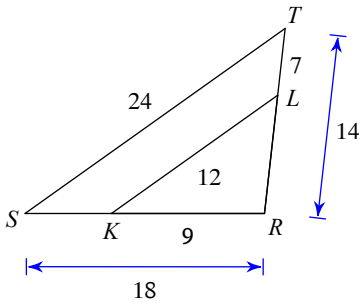

$\triangle RST \sim$ _____

2)

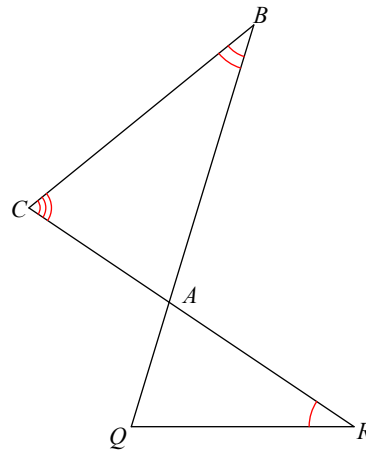

$\triangle ABC \sim$ _____

3)

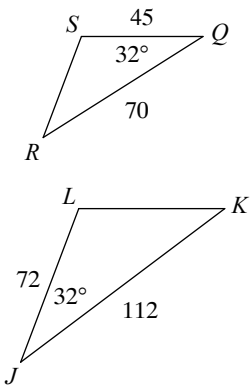

$\triangle JKL \sim$ _____

4)

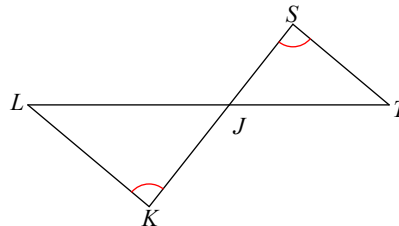

$\triangle JKL \sim$ _____

5)

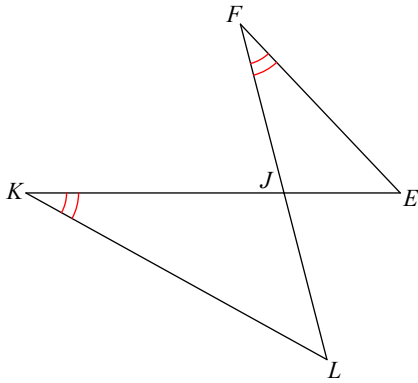

$\triangle JKL \sim$ _____

6)

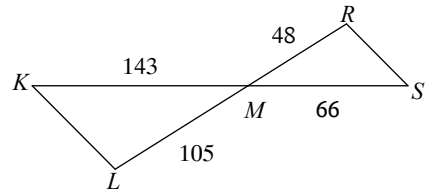

$\triangle MLK \sim$ _____

Find the missing length. The triangles in each pair are similar.

7) $\triangle BCD \sim \triangle LMN$

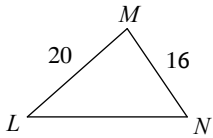
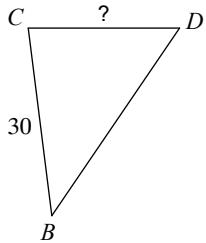

8) $\triangle ABC \sim \triangle LMN$

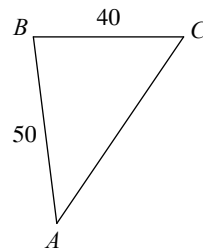
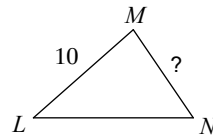

Solve for x . The triangles in each pair are similar.

9) $\triangle RST \sim \triangle RMN$

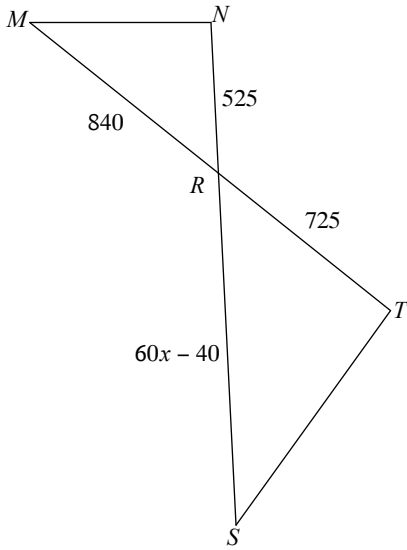

10)

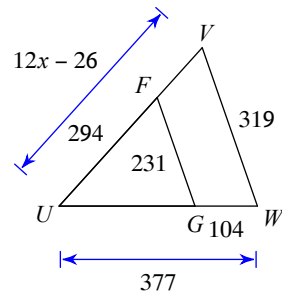

11) $\triangle DEF \sim \triangle KLM$

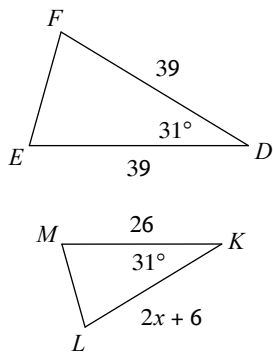

12) $\triangle DEF \sim \triangle NML$

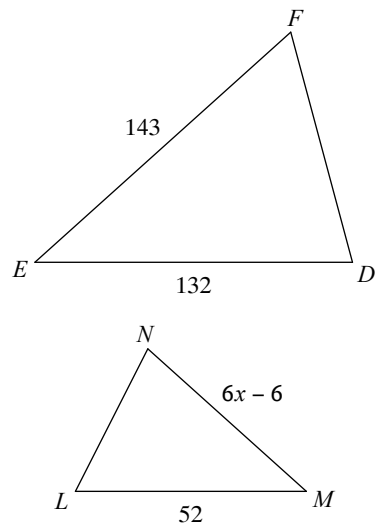

Applications using Similar Triangles

Using Shadows to Find Heights

Suppose you want to use the shadow method to estimate the height of a building. You make the following measurements:

- length of the stick: 3 m
- length of the stick's shadow: 1.5 m
- length of the building's shadow: 8 m

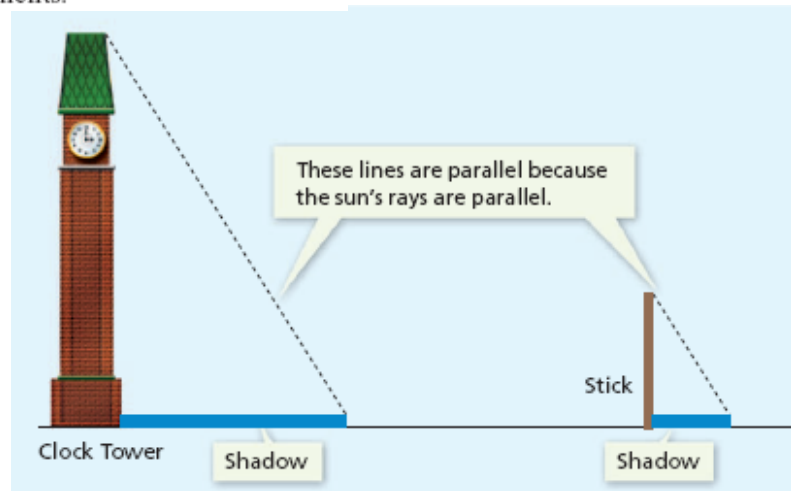

Using Mirrors to Find Heights

Jim wants to find the height of the traffic light.

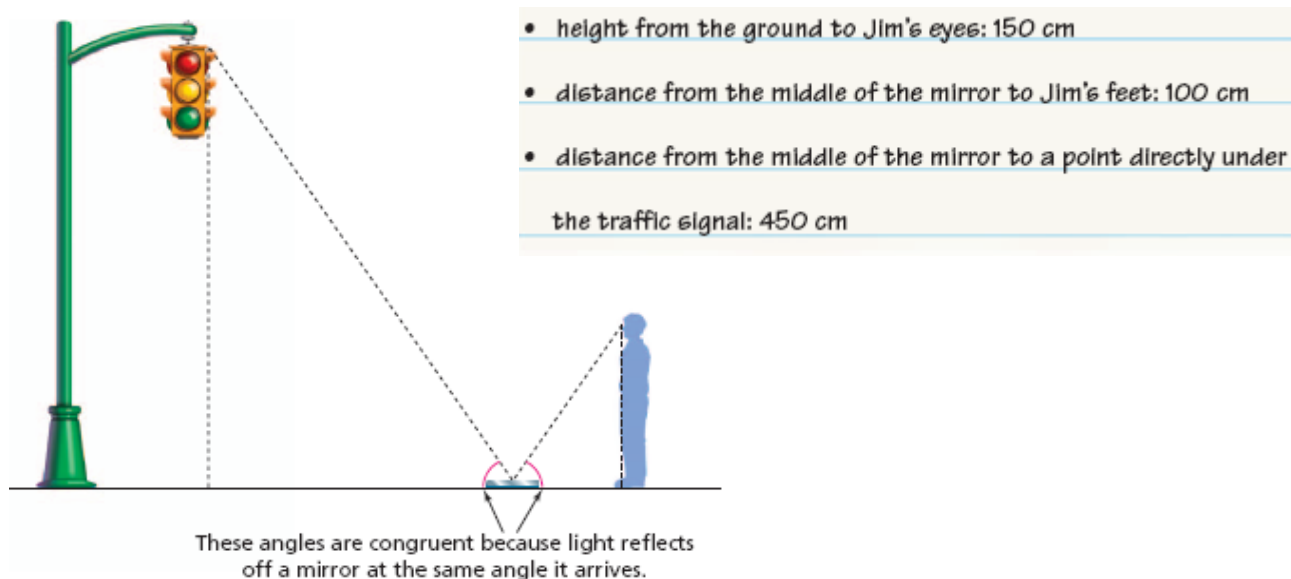

Name _____

Block _____

Application Problems using Similar Triangles

1) If a tree casts a 24-foot shadow at the same time that a yardstick casts a 2-foot shadow, find the height of the tree.

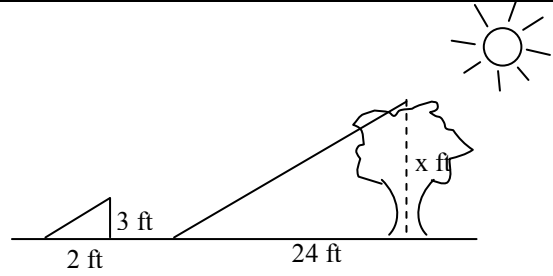

2) A bush is sighted on the other side of a canyon. Find the width of the canyon.

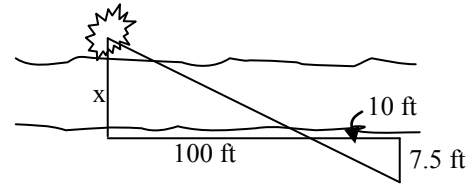

3) A 12-centimeter rod is held between a flashlight and a wall as shown. Find the length of the shadow on the wall if the rod is 45 cm from the wall and 15 cm from the light.

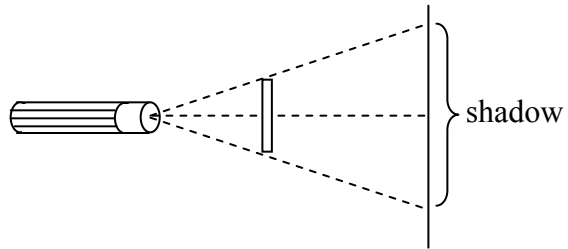

4) The cheerleaders at City High make their own megaphones by cutting off the small end of a cone made from heavy paper. If the small end of the megaphone is to have a radius of 2.5 cm, what should be the height of the cone that is cut off?

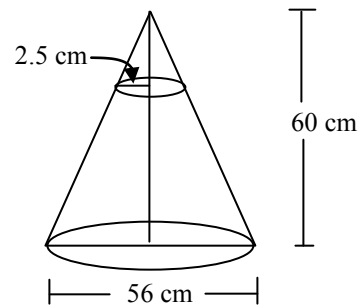

5) Find the width of the Brady River.

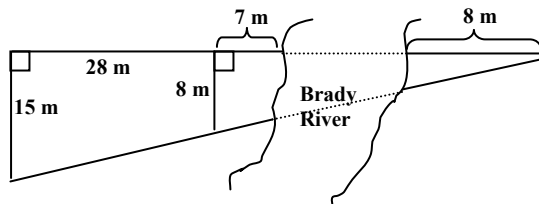

6) The foot of a ladder is 1.2 m from a fence that is 1.8 m high. The ladder touches the fence and rests against a building that is 1.8 m behind the fence. Draw a diagram, and determine the height on the building reached by the top of the ladder.

7) Ramon places a mirror on the ground 45 ft from the base of a geyser. He walks backward until he can see the top of the geyser in the middle of the mirror. At that point, Ramon's eyes are 6 ft above the ground and he is 7.5 ft from the mirror. Use similar triangles to find the height of the geyser.

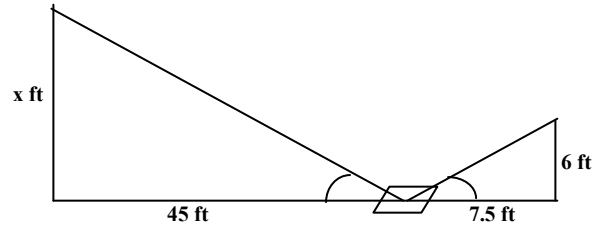

8) Find the height of the giraffe in the diagram below.

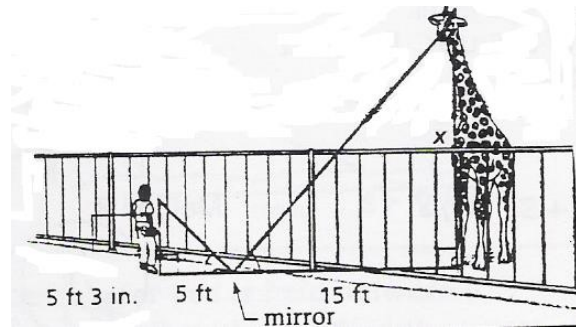

9) On level ground, the base of a tree is 20 ft from the bottom of a 48-ft flagpole. The tree is shorter than the pole. At a certain time, their shadows end at the same point 60 ft from the base of the flagpole. How tall is the tree?

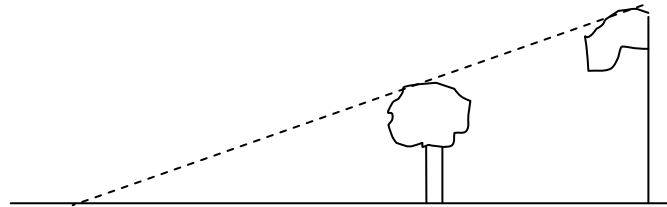

10) Mason Construction wants to connect two parks on opposite sides of town with a road. Surveyors have laid out a map as shown. The road can be built through the town or around town through point R. The roads intersect at a right angle at point R. The line joining Park A to Park B is parallel to the line joining C and D.

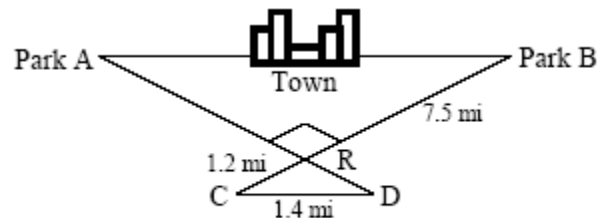

a. What is the distance between the parks through town?

Note: The figure is not drawn to scale.

b. What is the distance from Park A to Park B through point R?

11) A tree casts a shadow that is 24 feet long. A person who is 5 feet tall is standing in front of the tree, and his shadow is 8 feet long. Approximately how tall is the tree?

