

Name: \_\_\_\_\_

# Similar Triangles and Trigonometry

*Unit Outline:*

- a. Review of Angle Theorems
- b. Similar Triangles
- c. Right Angle Triangle Ratios
- d. Solving Triangles using Primary Trigonometric Ratios SOH CAH TOA
- e. Sine Law
- f. Cosine Law

## Formula Sheet

### Pythagorean Theorem:

$$c^2 = a^2 + b^2$$

### Right Angle Triangles SOHCAHTOA

$$\sin(A) = \frac{\text{opposite}}{\text{hypotenuse}} = \frac{a}{c}$$

$$\cos(A) = \frac{\text{adjacent}}{\text{hypotenuse}} = \frac{b}{c}$$

$$\tan(A) = \frac{\text{opposite}}{\text{adjacent}} = \frac{a}{b}$$

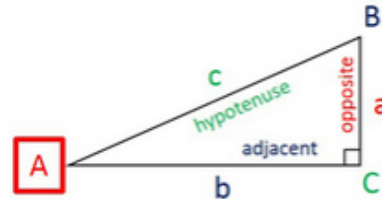

### Sine Law

For the Sine Law we need:

- An angle and its opposite side, and one other piece of information.
- OR SAS, ASA [and ASS (use with caution!)]

$$\frac{a}{\sin A} = \frac{b}{\sin B} = \frac{c}{\sin C} \quad \text{or} \quad \frac{\sin A}{a} = \frac{\sin B}{b} = \frac{\sin C}{c}$$

The length of any side, divided by the Sine of its opposite angle is the same for all three pairs

If we are trying to **find an angle**, use the first form of the Sine Law (**angles on top**)

If we are trying to **find the length** of a side, use the second form of the law (**with sides on top**)

### Cosine Law

For the Cosine Law we need:

- 2 sides and the included angle.
- 3 sides

To find a side (have SAS):

$$a^2 = b^2 + c^2 - 2bc \cos A$$

$$b^2 = a^2 + c^2 - 2ac \cos B$$

$$c^2 = a^2 + b^2 - 2ab \cos C$$

To find an angle (have SSS):

$$\cos A = \frac{b^2 + c^2 - a^2}{2bc}$$

$$\cos B = \frac{a^2 + c^2 - b^2}{2ac}$$

$$\cos C = \frac{a^2 + b^2 - c^2}{2ab}$$

# Lesson 3.0 - Trigonometry Prerequisite Skills

A Solving for  $x$ , to 2 decimal places if necessary.

$$x^2 = 100$$

$$x = \sqrt{100}$$

$$x = \pm 10$$

$x_1 = 10$        $x_2 = -10$

$$x^2 = 3^2 + 4^2$$

$$x^2 = 9 + 16$$

$$x^2 = 25$$

$$x = \sqrt{25}$$

$$x = \pm 5$$

$$+8^2 + x^2 = 12^2$$

$$x^2 = 12^2 - 8^2$$

$$x^2 = 144 - 64$$

$$x^2 = 80$$

$$x = \sqrt{80}$$

$$x \approx \pm 8.94$$

B The Pythagorean Theorem: Find the unknown side.

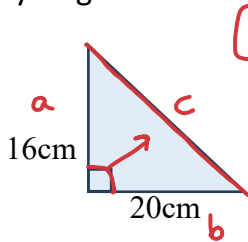

$$c^2 = a^2 + b^2$$

$$c^2 = 16^2 + 20^2$$

$$c^2 = 256 + 400$$

$$c^2 = 656$$

$$c = \sqrt{656} \approx 25.6$$

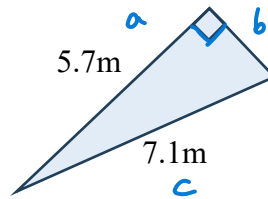

$$c^2 = a^2 + b^2$$

$$7.1^2 = 5.7^2 + b^2$$

$$50.41 = 32.49 + b^2$$

$$50.41 - 32.49 = b^2$$

$$17.92 = b^2$$

$$b = \sqrt{17.92} \approx 4.2$$

C Angle Theorems

Sum of a Triangle:

Angles in a triangle add up to 180°

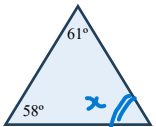

$$x = 180 - (61 + 58)$$

$$x = 61^\circ$$

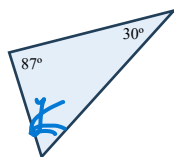

$$y = 180 - (87 + 30)$$

$$y = 63^\circ$$

Comp  $\angle$ s add to 90°

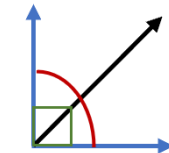

Complementary

$$\text{Comp}(90^\circ) = 0^\circ$$

$$\text{Comp}(45^\circ) = 45^\circ$$

$$\text{Comp}(30^\circ) = 60^\circ$$

Supp  $\angle$ s add to 180°

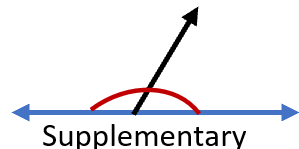

Supplementary

$$\text{Supp}(90^\circ) = 90^\circ$$

$$\text{Supp}(60^\circ) = 120^\circ$$

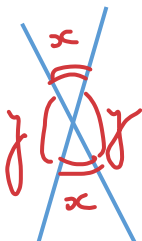

OPPOSITE ANGLES are ALWAYS EQUAL.

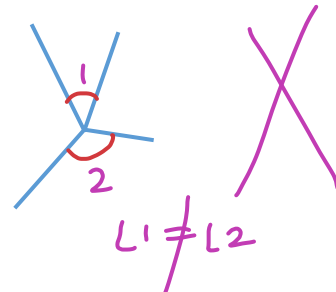

Let's now check if we remember any angle patterns from our elementary school geometry lessons ;)

Calculate the missing angle and give a reason for your answer.

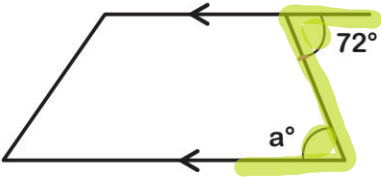

Angle a:	Reason:
72°	Z-pattern

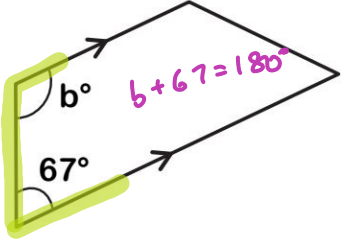

Angle b:	Reason:
180 - 67 = 113°	C-pattern

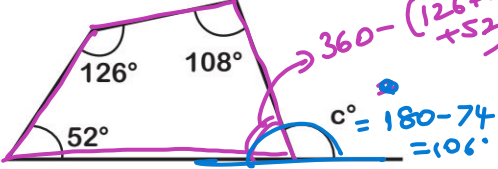

Angle c:	Reason:
106°	Angle Sum prop. Straight line

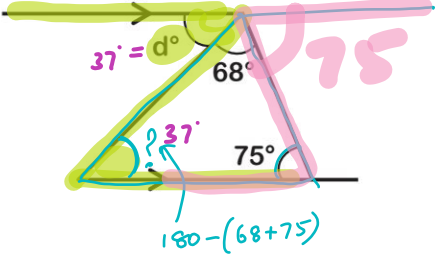

Angle d:	Reason:
37°	Angle Sum Property. Z-pattern

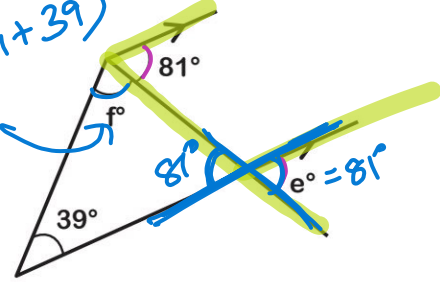

Angle e:	Reason:
81°	F-pattern

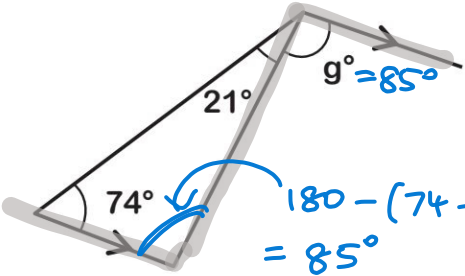

Angle g:	Reason:
85°	A.S.P. Z-pattern

Angle f:	Reason:
60°	opposite angles Angle Sum prop.

Angle g:	Reason:
85°	A.S.P. Z-pattern

\* Parallel Lines intersected by a TRANSVERSAL

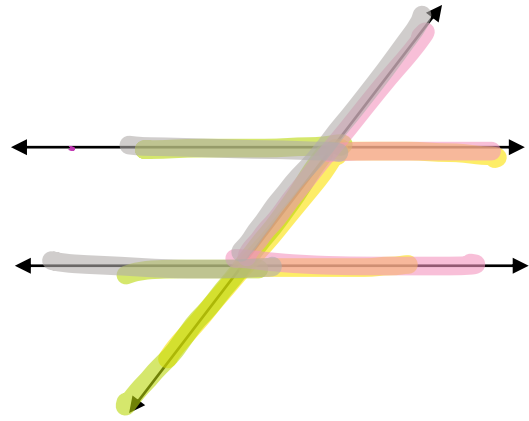

Alternate Angles (Z)



EQUAL

Co-Interior Angles (C)



$$x + y = 180^\circ$$

Corresponding Angles (F)



EQUAL

D Solving Proportions

a)  $\frac{3}{a} = \frac{5}{9}$

CROSS MULTIPLY

$$3(9) = 5(a)$$

$$\frac{27}{5} = \frac{5a}{5}$$

$$\frac{27}{5} = a$$

b)  $\frac{x}{19} = \frac{2.3}{3}$

$$x = \frac{2.3 \times 19}{3}$$

$$x \approx 14.57$$

c)  $\frac{2}{(x+7)} = \frac{4}{11}$

$$2(11) = 4(x+7)$$

$$22 = 4x + 28$$

$$22 - 28 = 4x$$

$$\frac{-6}{4} = \frac{4x}{4}$$

$$-1.5 = x$$

d)  $\frac{4}{(x-5)} = \frac{8}{(x+3)}$

$$\Rightarrow 4(x+3) = 8(x-5)$$

$$\Rightarrow 4x + 12 = 8x - 40$$

$$\Rightarrow 12 + 40 = 8x - 4x$$

$$\Rightarrow \frac{52}{4} = \frac{4x}{4}$$

$$\Rightarrow 13 = x$$

# Lesson 3.1 Congruence and Similarity in Triangles

**Congruent Triangles** are triangles which

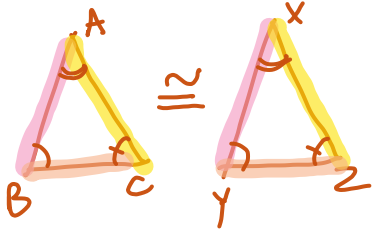

$$\triangle ABC \cong \triangle XYZ$$

$$AB = XY \quad LA = LX$$

$$BC = YZ \quad LB = LY$$

$$AC = XZ \quad LC = LZ$$

SCALENE  $\triangle$   
All Unequal Sides.



ISOSCELES  $\triangle$

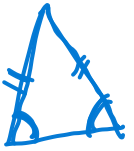

EQUILATERAL  $\triangle$



RIGHT  $\triangle$

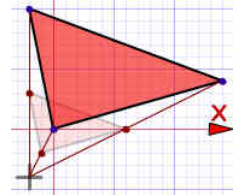
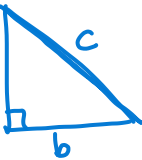

$$c^2 = a^2 + b^2$$

**Similar triangles** are triangles which have the **exact same angle measures** but the side lengths have a different scale i.e. side lengths may be resized. The **scale factor** which is a ratio of corresponding side lengths states how much bigger (or smaller) the second triangle is compared to the first triangle through **proportions**. You can use this proportion to solve for the unknown side lengths.

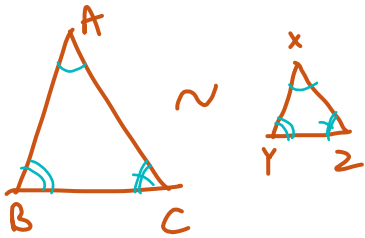

$$\triangle ABC \sim \triangle XYZ$$

$$\angle A = \angle X$$

$$\angle B = \angle Y$$

$$\angle C = \angle Z$$

$$\frac{AB}{XY} = \frac{BC}{YZ} = \frac{AC}{XZ}$$

ANGLES are EQUAL

SIDES are PROPORTIONAL

The following are similar triangles. Solve for unknown sides.

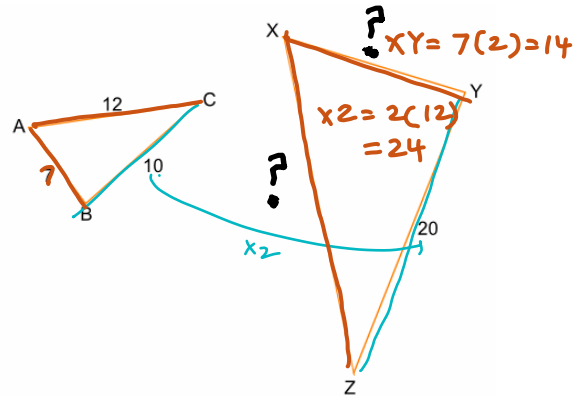
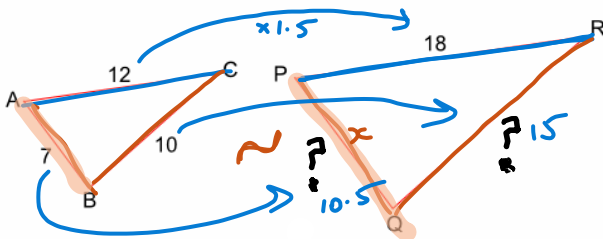

$$\frac{PR}{AC} = \frac{18}{12} = 1.5$$

$$\frac{PR}{AC} = \frac{PQ}{AB} = \frac{QR}{BC}$$

$$PQ = 7 \times 1.5 = 10.5$$

$$\frac{18}{12} = \frac{PQ}{7} = \frac{QR}{10}$$

$$QR = 10 \times 1.5 = 15$$

$$\frac{18}{12} = \frac{PQ}{7}$$

$$\frac{18}{12} = \frac{QR}{10}$$

$$7 \times \frac{18}{12} = PQ$$

$$\frac{10 \times 18}{12} = QR$$

$$10.5 = PQ$$

$$15 = QR$$

**Mathematical Notation:**

The ~ symbol is used to indicate similarity. The ≅ symbol is used to indicate congruence.

**When naming triangles that are congruent or similar, the corresponding vertices must be listed in the same order.**

For example, if  $\angle A = \angle D$ ,  $\angle B = \angle E$  and  $\angle C = \angle F$ , then  $\triangle ABC \sim \triangle DEF$ . ( $ABC \neq EDF$ )

$\triangle ABC \sim \triangle RST$ . Complete each statement.

- a)  $\angle ABC = \underline{\angle RST}$
- b)  $\angle BCA = \underline{\angle STR}$
- c)  $\frac{AB}{RS} = \frac{BC}{ST} = \frac{AC}{RT}$
- d)  $\triangle STR \sim \underline{\triangle BCA}$
- e)  $\frac{ST}{BC} = \frac{RT}{AC} = \frac{RS}{AB}$
- f)  $\angle SRT = \underline{\angle BAC}$

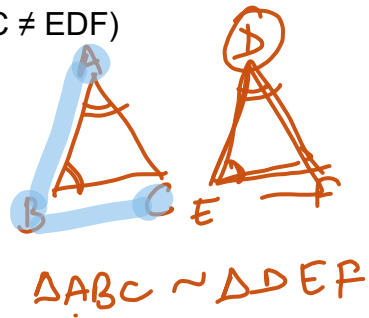
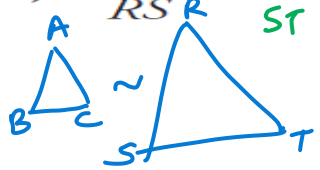

**But How Do You Know the given Triangles are SIMILAR?**

Properties of Similar Triangles – Symbol: ~

- Similar triangles have the exact same shape BUT have a different scale

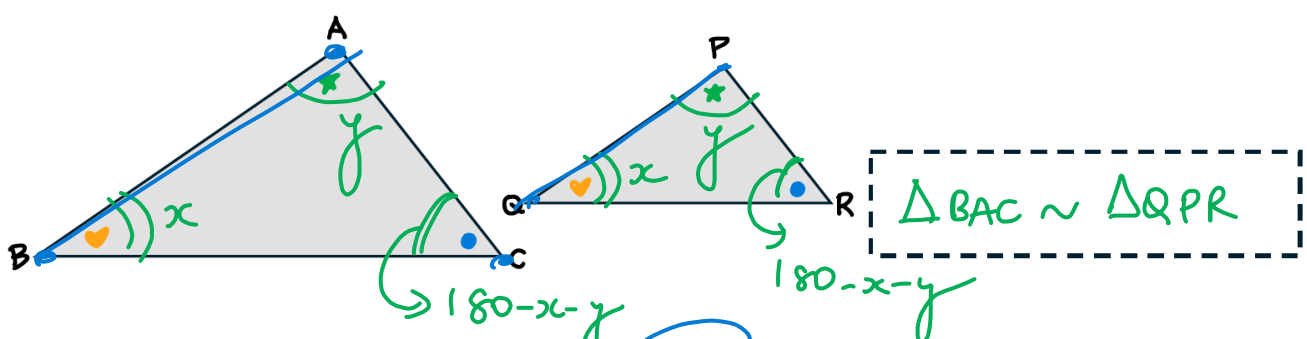

PROOF #1: Show that all three angles are equal (AAA)

$$\begin{aligned} \angle ABC &= \angle PQR \\ \angle BAC &= \angle QPR \\ \angle ACB &= \angle PRQ \end{aligned}$$

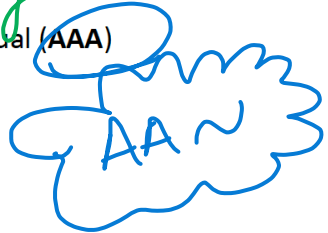

PROOF #2: Show that the ratios of the corresponding side lengths are equal (SSS)

$$\frac{AB}{PQ} = \frac{BC}{QR} = \frac{AC}{PR}$$

PROOF #3: (SAS) Show that 2 ratios of corresponding sides are equal and 1 angle is equal.

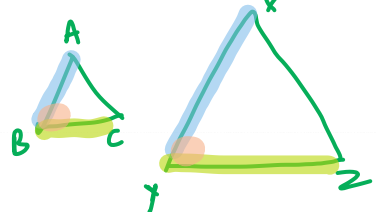

$$\begin{aligned} \angle B &= \angle Y \\ \frac{AB}{XY} &= \frac{BC}{YZ} \end{aligned}$$

Similarity Proofs	
<b>Angle-Angle (AA)</b>	If two angles of one triangle are congruent to two angles of another triangle, the triangles are similar.
<b>SSS</b> proportional	If the three sets of corresponding sides of two triangles are <b>in proportion</b> , the triangles are similar.
<b>SAS</b> proportional	If an angle of one triangle is congruent to the corresponding angle of another triangle and the lengths of the sides including these angles are <b>in proportion</b> , the triangles are similar.

1. Is  $\triangle DEF$  similar to  $\triangle ABC$ ?

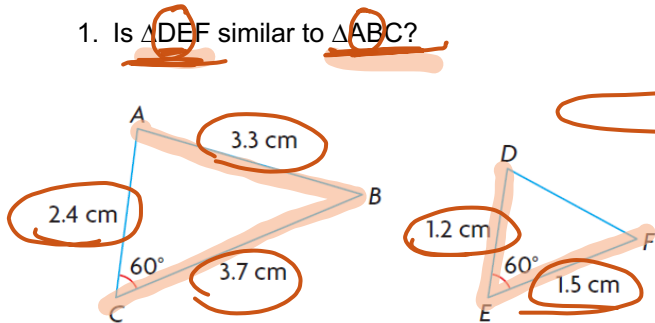

$$\frac{DE}{AB} = \frac{EF}{BC} = \frac{DF}{AC}$$

$$\angle D = \angle A$$

$$\angle E = \angle B$$

$$\angle F = \angle C$$

\* In this,

→ the Naming of the triangles don't match.

→ the sides are not proportional

2. Is  $\triangle DEF$  similar to  $\triangle ACB$ ?  
What is the length of side DF?

Provide Statement-Reason Proof.

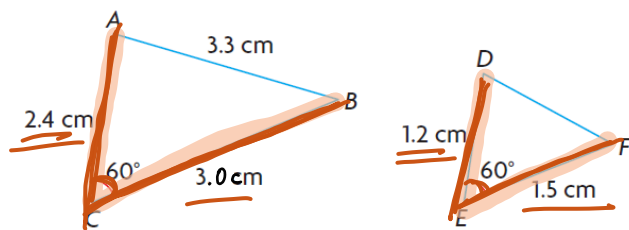

$$\frac{AC}{DE} = \frac{2.4}{1.2} = 2$$

$$\frac{CB}{EF} = \frac{3.0}{1.5} = 2$$

$$\frac{AC}{DE} = \frac{CB}{EF}$$

$$\angle C = \angle E = 60^\circ$$

$$\triangle DEF \sim \triangle ACB \text{ (SAS)} \sim$$

$$\therefore DF = \frac{3.3}{2} = 1.65 \text{ cm (Corresponding side of } \sim \Delta s)$$

**Practice Example**

1. Is  $\triangle ABC \sim \triangle DEF$ ? Justify your answer.

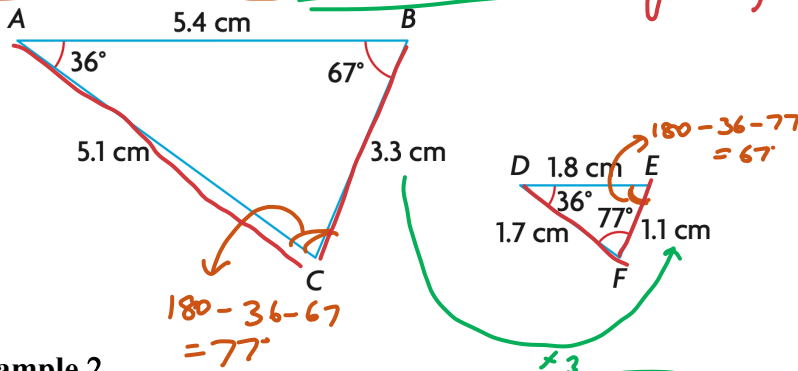

**METHOD 1:**

$\angle A = \angle D (= 36^\circ)$   
 $\angle B = \angle E (= 67^\circ)$   
 $\therefore \triangle ABC \sim \triangle DEF (AA \sim)$

**METHOD 2:**

$\frac{BC}{EF} = \frac{3.3}{1.1} = 3$        $\frac{AB}{DE} = \frac{5.4}{1.8} = 3$   
 $\frac{AC}{DF} = \frac{5.1}{1.7} = 3$

$\therefore \frac{BC}{EF} = \frac{AC}{DF} = \frac{AB}{DE}$   
 $\triangle ABC \sim \triangle DEF (SSS \sim)$

**METHOD 3:**  
 SAS  $\sim$

**Example 2.**

Suppose that  $\triangle PQR \sim \triangle LMN$  and  $\angle P = 90^\circ$ .

- a) What angle in  $\triangle LMN$  equals  $90^\circ$ ? How do you know?
- b) If  $MN = 13$  cm,  $LN = 12$  cm,  $LM = 5$  cm, and  $PQ = 15$  cm, what are the lengths of  $PR$  and  $QR$ ?

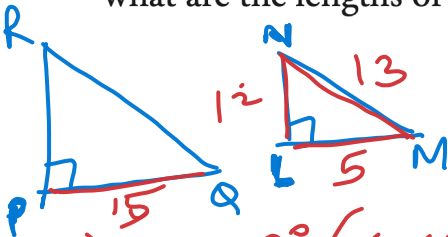

a)  $\angle L = 90^\circ$  (corresponding angle of  $\sim \Delta s$ )

b)  $\frac{PQ}{LM} = \frac{15}{5} = 3 \therefore PR = 3(12) = 36$  cm  
 $RQ = 3(13) = 39$  cm.

**Example 3.** Shiva is standing beside a lighthouse on a sunny day, as shown. She measures the length of her shadow and the length of the shadow cast by the lighthouse. Shiva is 1.6 m tall. How tall is the lighthouse?

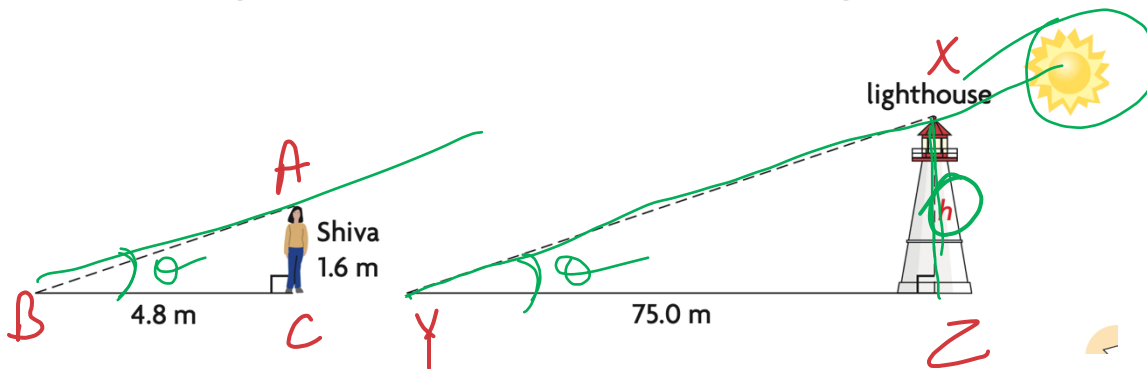

$\angle B = \angle Y$  (Angle made by the Sun)

$\angle C = \angle Z (= 90^\circ)$

$\therefore \triangle ABC \sim \triangle XYZ (AA \sim)$

$\therefore \frac{h}{75} = \frac{1.6}{4.8} \Rightarrow h = \frac{1.6}{4.8} \times 75 = 25$

$\therefore$  The lighthouse is 25m tall.

### Example 4

- a) Show that the two triangles to the right are similar, with reasons.  
 b) Determine  $x$  and  $y$

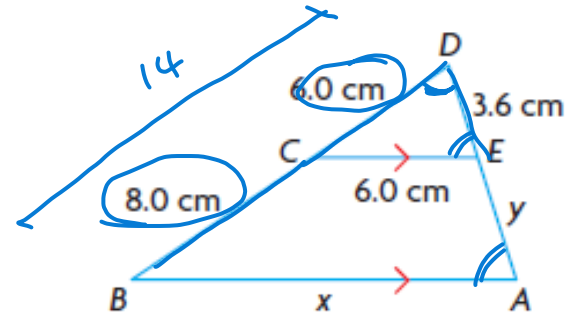

Statement	Reason
$\angle D = \angle D$	(Common angle)
$\angle E = \angle A$	(F-pattern)
$\therefore \triangle DEC \sim \triangle DAB$	(AA~)

$$\Rightarrow \frac{DE}{DA} = \frac{EC}{AB} = \frac{DC}{DB} \Rightarrow \frac{3.6}{3.6+y} = \frac{6}{x} = \frac{6}{14}$$

$$\frac{6}{x} = \frac{6}{14} \Rightarrow x = 14$$

$$\frac{3.6}{(3.6+y)} = \frac{6}{14}$$

$$7(3.6) = 3(3.6+y)$$

$$25.2 = 10.8 + 3y$$

$$25.2 - 10.8 = 3y$$

$$\frac{14.4}{3} = y$$

$$4.8 = y$$

### Example 5

A new bridge is going to be built across a river, but the width of the river cannot be measured directly. Surveyors set up posts at points A, B, C, D and E. Then they took measurements relative to the posts.

What is the width of the river?

- a) Show that the two triangles in this diagram are similar.  
 b) Determine the width of the river

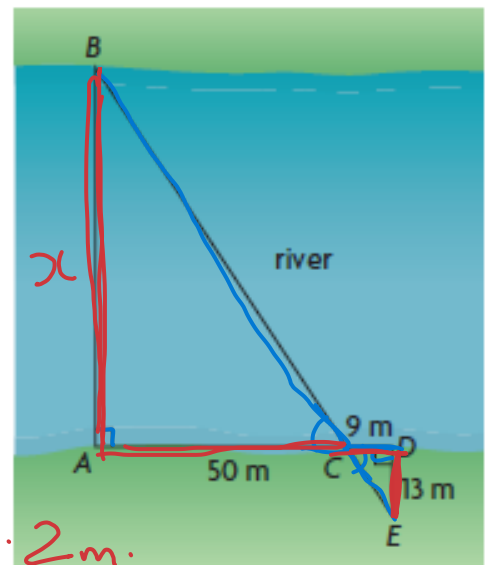

Statement	Reason
$\angle A = \angle D (= 90^\circ)$	
$\angle BCA = \angle ECD$ (opposite angles)	
$\therefore \triangle BCA \sim \triangle ECD$ (AA~)	

$$\therefore \frac{x}{13} = \frac{50}{9} \Rightarrow x = \frac{50 \times 13}{9} = 72.2 \text{ m.}$$

$\therefore$  The width of the river is 72.2 m.

In order to solve "real world problems" you have to be SURE that the triangles you are working with are similar. All that is needed for proof of similarity is AA similarity.

# Lesson 3.2a Exploring Similar Right Angle Triangles

$\triangle ADE \sim \triangle AFG$  therefore  $AD \sim AF$   
 $AE \sim AG$   
 $DE \sim FG$

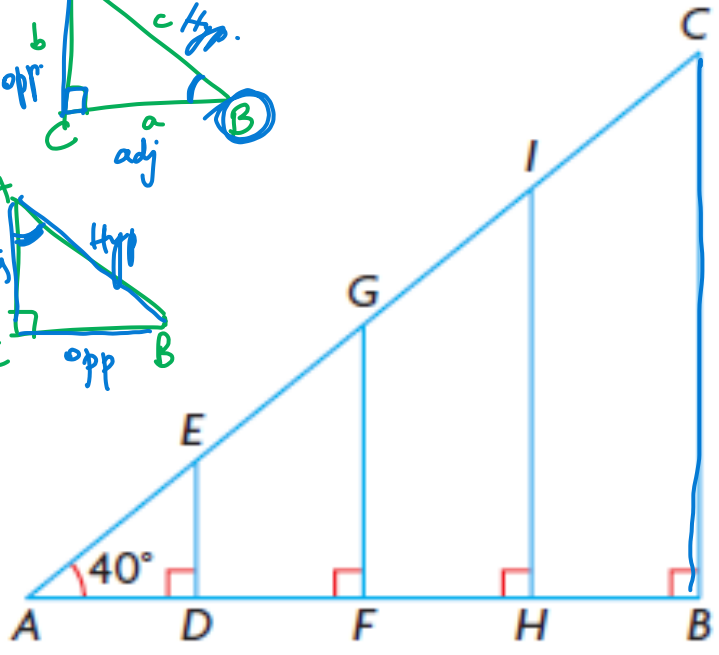
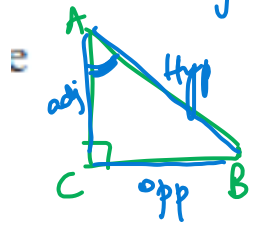
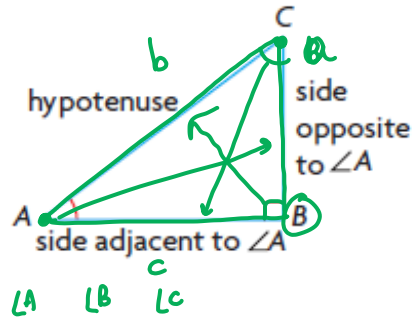
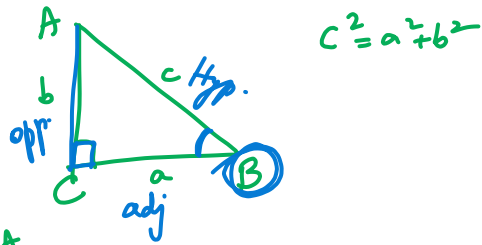

Use a ruler and measure the side lengths then calculate the ratios.

Triangle	Side OPPOSITE to $\angle A$	Side ADJACENT to $\angle A$	HYPOTENUSE	Trigonometric Ratios		
				OPPOSITE HYPOTENUSE	ADJACENT HYPOTENUSE	OPPOSITE ADJACENT
$\triangle ABC$	$BC = 7$	$AB = 8.5$	$AC = 11$	$\frac{BC}{AC} = 0.6$	$\frac{AB}{AC} = 0.8$	$\frac{BC}{AB} = 0.8$
$\triangle ADE$	$DE = 1.5$	$AD = 2$	$AE = 2.8$	$\frac{DE}{AE} = 0.6$	$\frac{AD}{AE} = 0.8$	$\frac{DE}{AD} = 0.8$
$\triangle AFG$	$FG = 3.5$	$AF = 4.3$	$AG = 5.5$	$\frac{FG}{AG} = 0.6$	$\frac{AF}{AG} = 0.8$	$\frac{FG}{AF} = 0.8$
$\triangle AHI$	$HI = 5.2$	$AH = 6.5$	$AI = 8.4$	$\frac{HI}{AI} = 0.6$	$\frac{AH}{AI} = 0.8$	$\frac{HI}{AH} = 0.8$

So, instead of saying  $\frac{opp}{hyp}$ , we call this ratio Sine, and for  $\frac{adj}{hyp}$  Cosine and for  $\frac{opp}{adj}$  Tangent

Sin
Cos
Tan

Mathematicians have calculated the side ratios for each possible angle and programmed the algorithms necessary into the scientific calculators. Even triangles with angles to the hundredth decimal place can be solved!

Angle	Sine	Cosine	Tangent	Angle	Sine	Cosine	Tangent
1°	.0175	.9998	.0175	46°	.7193	.6947	1.0355
2°	.0349	.9994	.0349	47°	.7314	.6820	1.0724
3°	.0523	.9986	.0524	48°	.7431	.6691	1.1106
4°	.0698	.9976	.0699	49°	.7547	.6561	1.1504
5°	.0872	.9962	.0875	50°	.7660	.6428	1.1918
6°	.1045	.9945	.1051	51°	.7771	.6293	1.2349
7°	.1219	.9925	.1228	52°	.7880	.6157	1.2799
8°	.1392	.9903	.1405	53°	.7986	.6018	1.3270
9°	.1564	.9877	.1584	54°	.8090	.5878	1.3764
10°	.1736	.9848	.1763	55°	.8192	.5736	1.4281
11°	.1908	.9816	.1944	56°	.8290	.5592	1.4826
12°	.2079	.9781	.2126	57°	.8387	.5446	1.5399
13°	.2250	.9744	.2309	58°	.8480	.5299	1.6003
14°	.2419	.9703	.2493	59°	.8572	.5150	1.6643
15°	.2588	.9659	.2679	60°	.8660	.5000	1.7321
16°	.2756	.9613	.2867	61°	.8746	.4848	1.8040
17°	.2924	.9563	.3057	62°	.8829	.4695	1.8807
18°	.3090	.9511	.3249	63°	.8910	.4540	1.9626
19°	.3256	.9455	.3443	64°	.8988	.4384	2.0503
20°	.3420	.9397	.3640	65°	.9063	.4226	2.1445
21°	.3584	.9336	.3839	66°	.9135	.4067	2.2460
22°	.3746	.9272	.4040	67°	.9205	.3907	2.3559
23°	.3907	.9205	.4245	68°	.9272	.3746	2.4751
24°	.4067	.9135	.4452	69°	.9336	.3584	2.6051
25°	.4226	.9063	.4663	70°	.9397	.3420	2.7475
26°	.4384	.8988	.4877	71°	.9455	.3256	2.9042
27°	.4540	.8910	.5095	72°	.9511	.3090	3.0777
28°	.4695	.8829	.5317	73°	.9563	.2924	3.2709
29°	.4848	.8746	.5543	74°	.9613	.2756	3.4874
30°	.5000	.8660	.5774	75°	.9659	.2588	3.7321
31°	.5150	.8572	.6009	76°	.9703	.2419	4.0108
32°	.5299	.8480	.6249	77°	.9744	.2250	4.3315
33°	.5446	.8387	.6494	78°	.9781	.2079	4.7046
34°	.5592	.8290	.6745	79°	.9816	.1908	5.1446
35°	.5736	.8192	.7002	80°	.9848	.1736	5.6713
36°	.5878	.8090	.7265	81°	.9877	.1564	6.3138
37°	.6018	.7986	.7536	82°	.9903	.1392	7.1154
38°	.6157	.7880	.7813	83°	.9925	.1219	8.1443
39°	.6293	.7771	.8098	84°	.9945	.1045	9.5144
40°	.6428	.7660	.8391	85°	.9962	.0872	11.4301
41°	.6561	.7547	.8693	86°	.9976	.0698	14.3007
42°	.6691	.7431	.9004	87°	.9986	.0523	19.0811
43°	.6820	.7314	.9325	88°	.9994	.0349	28.6363
44°	.6947	.7193	.9657	89°	.9998	.0175	57.2900
45°	.7071	.7071	1.0000				

Having observed now that sides and angles of triangles are connected and related in so many different ways, we are ready to formally move into a brand-new branch of Mathematics called TRIGONOMETRY 😊

**TRIGONOMETRY is the branch of Mathematics that deals with the properties of triangles and calculations based on these properties.** As you will find out soon, Trigonometry has a lot of advantages in helping us solve real world problems.

## Lesson 3.2b The Primary Trigonometric Ratios

Given the Right  $\triangle ABC$

We use  $\theta$  (Theta) to indicate angle in geometry.

For any one of the two **non-right angles**  $\theta$ , we have an **adjacent side** and an **opposite side**.

In the given triangle,

c - **HYPOTENUSE**

a - **ADJACENT**

b - **OPPOSITE**

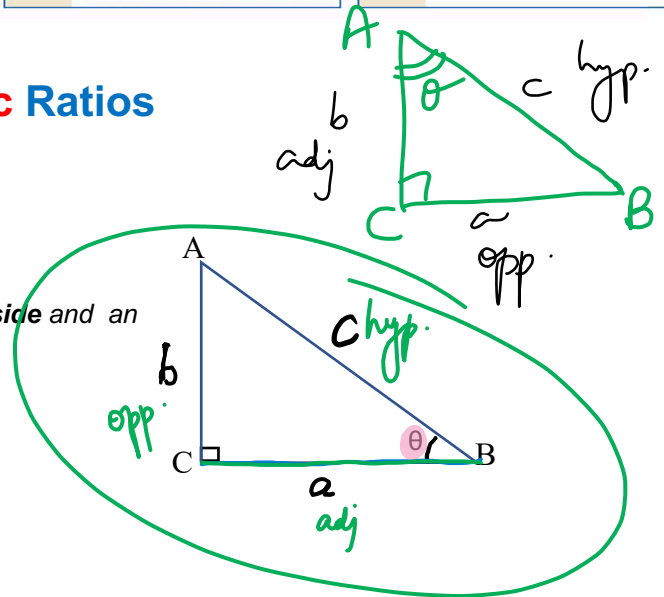

### The Trig Ratios

$$\text{Sine: } \sin \theta = \frac{\text{opp}}{\text{hyp}} = \frac{b}{c}$$

$$\text{Cosine: } \cos \theta = \frac{\text{adj}}{\text{hyp}} = \frac{a}{c}$$

$$\text{Tangent: } \tan \theta = \frac{\text{opp}}{\text{adj}} = \frac{b}{a}$$

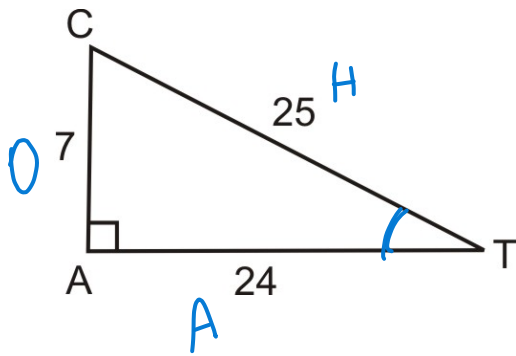

Examples  $\triangle ACT$

$$\text{Sine: } \sin T = \frac{O}{H} = \frac{7}{25}$$

$$\text{Cosine: } \cos T = \frac{A}{H} = \frac{24}{25}$$

$$\text{Tangent: } \tan T = \frac{O}{A} = \frac{7}{24}$$

What is the Value of  $\angle T$ ?

Sine

$$\sin T = \frac{7}{25}$$

$$T = \sin^{-1}\left(\frac{7}{25}\right)$$

$$T \approx 16^\circ$$

Cosine

$$\cos T = \frac{24}{25}$$

$$T = \cos^{-1}\left(\frac{24}{25}\right)$$

$$T \approx 16^\circ$$

Tangent

$$\tan T = \frac{7}{24}$$

$$T = \tan^{-1}\left(\frac{7}{24}\right)$$

$$T \approx 16^\circ$$

# SOH CAH TOA

Let's Practice on our Scientific Calculators some more:

1. Find the value of each trigonometric ratio to the nearest ten-thousandth (4 decimal places)

a)  $\sin 45 =$

$0.7071$

b)  $\cos 38 =$

$0.7860$

c)  $\tan 80 =$

$5.6713$

2. Find each angle measure to the nearest degree

a)  $\sin \theta = 0.422618$

$\theta = \sin^{-1}(0.422618)$   
 $\theta \approx 25^\circ$

b)  $\cos \theta = 0.4393267$

$\theta = \cos^{-1}(0.4393267)$   
 $\theta \approx 64^\circ$

c)  $\tan \theta = 0.176327$

$\theta = \tan^{-1}(0.176327)$   
 $\theta \approx 10^\circ$

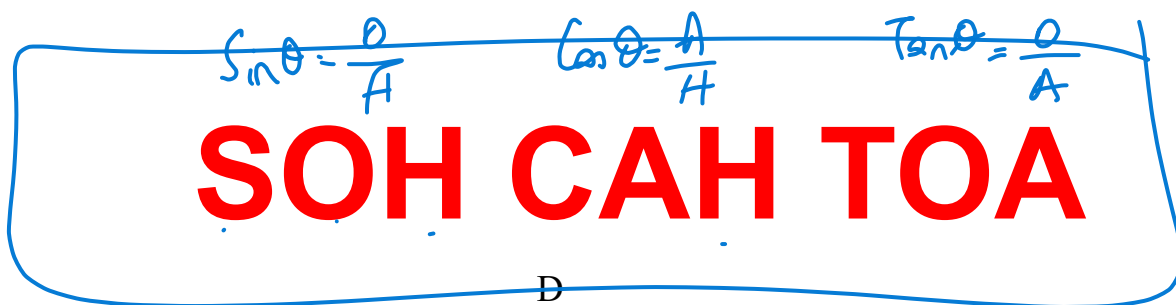

Given Right  $\triangle DEF$ , label

- The Hypotenuse side
- The Adjacent side
- The Opposite side

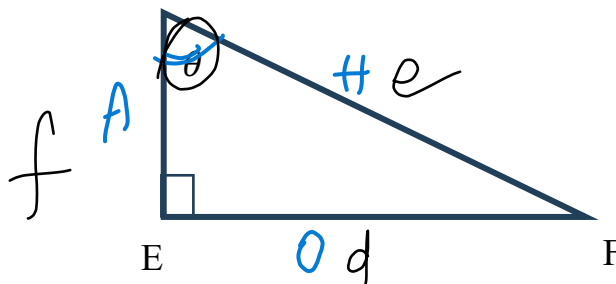

The 3 TRIG RATIOS:

Sine:  $\sin \theta = \frac{d}{e}$

SOH

Cosine:  $\cos \theta = \frac{f}{e}$

CAH

Tangent:  $\tan \theta = \frac{d}{f}$

TOA

## Lesson 3.3 Solving Right Angle Triangles

### Solving for Sides using the Primary Trigonometric Ratios

Solve for the unknown in the following:

$$\sin 35 = \frac{x}{8}$$
$$8 (\sin 35) = x$$
$$x \approx 4.6$$

$$\frac{\tan 62 = 3}{1} = \frac{3}{y}$$
$$y (\tan 62) = 3$$
$$y = \frac{3}{(\tan 62)}$$
$$y = 3 \div (\tan 62)$$
$$y \approx 1.6$$

**Notice:** Pay close attention to when the unknown is in the **numerator** and when the unknown is in the **denominator**.

- Steps to Solve:
1. Identify the **given angle** you are solving.
  2. Identify 1 **known** side and one **unknown** side.
  3. Write the appropriate **Trig Ratio** using #1 and 2 and **solve**

Solve for the unknown side in the following examples

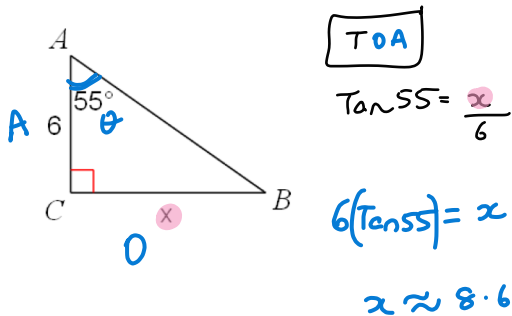

# SOH CAH TOA

# SOH CAH TOA

## Solving for Angles using the Primary Trigonometric Ratios

To solve for the angle, you must use the **INVERSE** function, which is  $\sin^{-1}$ ,  $\cos^{-1}$ ,  $\tan^{-1}$

Solve for  $\theta$  in the following examples

$$\sin\theta = 0.4782$$

$$\theta = \sin^{-1} 0.4782$$

$$\theta = 29^\circ \text{ (approx)}$$

$$\tan\theta = 2.01$$

$$\theta = \tan^{-1}(2.01)$$

$$\theta = 64^\circ \text{ (approx)}$$

$$\cos\theta = \frac{3}{5}$$

$$\theta = \cos^{-1}\left(\frac{3}{5}\right)$$

$$\theta \approx 53^\circ$$

Steps to Solve:

1. Identify the **angle** you are solving.
2. Identify 2 **known** sides.
3. Write the appropriate **Trig Ratio** using #2 and **solve**

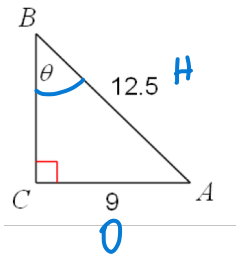

SOH

$$\sin\theta = \frac{9}{12.5}$$

$$\theta = \sin^{-1}\left(\frac{9}{12.5}\right)$$

$$\theta \approx 46^\circ$$

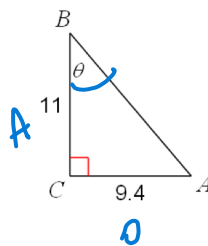

TOA

$$\tan\theta = \frac{9.4}{11}$$

$$\theta = \tan^{-1}\left(\frac{9.4}{11}\right)$$

$$\theta \approx 41^\circ$$

Solve the Triangle (Find ALL missing measurements)

In  $\triangle DEF$ ,  $\angle E = 90^\circ$ ,  $d = 7.2\text{cm}$ , and  $f = 5.8\text{cm}$ . Solve the triangle.

(Remember to draw Rough Figures always!! Math is a visual subject and Drawings are your best Friends!)

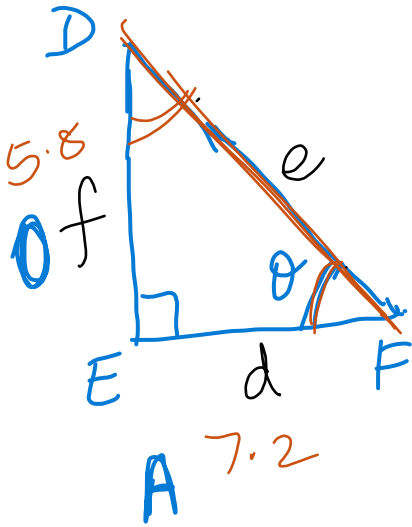

TOA

$$\tan \theta = \frac{5.8}{7.2}$$

$$\theta = \tan^{-1}\left(\frac{5.8}{7.2}\right)$$

$$\theta \approx 39^\circ = F$$

$$\therefore D = 180 - 90 - 39$$

$$D = 51^\circ$$

$$e^2 = d^2 + f^2$$

$$e = \sqrt{7.2^2 + 5.8^2}$$

$$e \approx 9.2$$

$$\begin{aligned} D &= 51^\circ \\ F &= 39^\circ \\ e &= 9.2 \text{ cm} \end{aligned}$$

# Lesson 3.4 Solving Right Triangle Real World Problems

## Angle of Elevation vs Angle of Depression

The word "elevation" means "rise" or "move up". Angle of elevation is the angle between the horizontal and the line of sight to an object above the horizontal.

The word "depression" means "fall" or "drop". Angle of depression is the angle between the horizontal and the line of sight to an object beneath the horizontal.

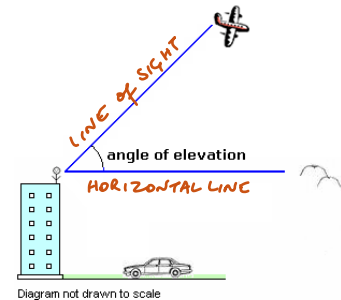
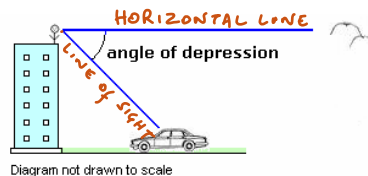

## Word Problems

#4 A tree that is 9.5 m tall casts a shadow that is 3.8 m long. What is the angle of elevation of the Sun?

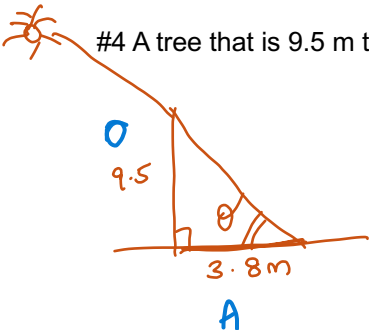

TOA  

$$\tan \theta = \frac{9.5}{3.8}$$

$$\theta = \tan^{-1}\left(\frac{9.5}{3.8}\right)$$

$$\theta \approx 68^\circ$$

∴ Angle of elevation of the Sun is 68° approx

#6 A building code states that a set of stairs cannot rise more than 72 cm for each 100 cm of run. What is the maximum angle at which the stairs can rise?

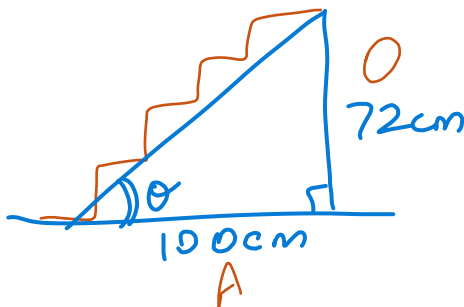

TOA  

$$\tan \theta = \frac{72}{100}$$

$$\theta = \tan^{-1}\left(\frac{72}{100}\right) \approx 36^\circ$$

∴ The stairs cannot have a slope of more than 36°

#8 Firefighters dig a triangular trench around a forest fire to prevent the fire from spreading. Two of the trenches are 800 m long and 650 m long. The angle between them is 36°. Determine the area that is enclosed by these trenches.

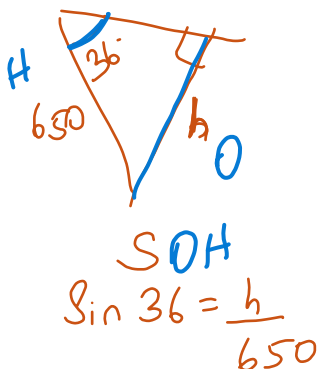

SOH  

$$\sin 36 = \frac{h}{650}$$

$$650 \sin 36 = h \approx 382.1 \text{ m}$$

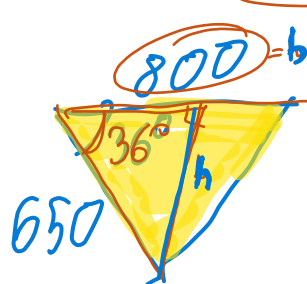

$$\text{Area}(\Delta) = \frac{bh}{2}$$

∴ Area enclosed by the trenches is 152850 m<sup>2</sup>

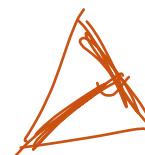

∴ Area =  $\frac{800(382.1)}{2}$

$$A \approx 152850 \text{ m}^2$$

#15 A video camera is mounted on top of a building that is 120 m tall. The angle of depression from the camera to the base of another building is  $36^\circ$ . The angle of elevation from the camera to the top of the same building is  $47^\circ$ . a) How far apart are the two buildings?

b) How tall is the building viewed by the camera?

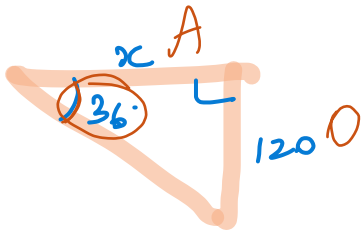

TOA

$$\tan 36 = \frac{120}{x}$$

$$x = \frac{120}{(\tan 36)}$$

$$x \approx 165.2$$

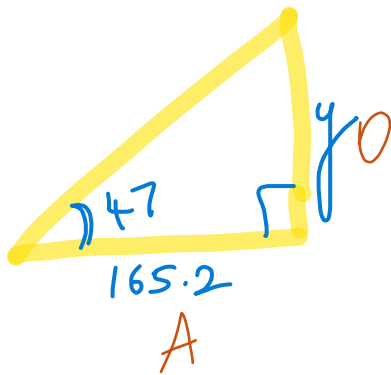

TOA

$$\tan 47 = \frac{y}{165.2}$$

$$165.2 (\tan 47) = y$$

$$y \approx 177.2$$

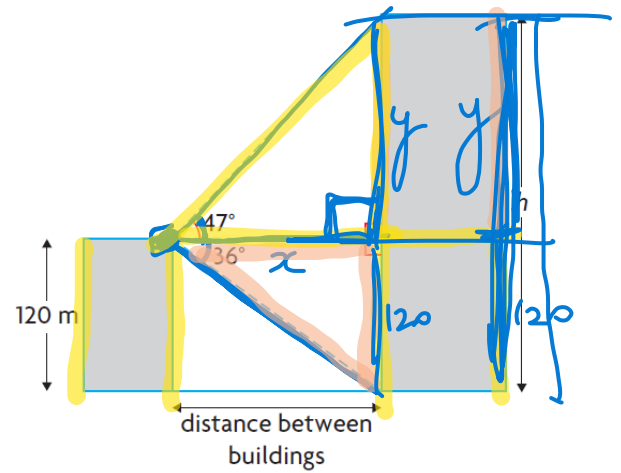

$$h = y + 120$$

$$\therefore h = 177.2 + 120$$

$$\approx 297.2 \text{ m.}$$

Understand that solving problems involves drawing a picture and then developing a plan to solve for the unknown.

This may take several steps, PATIENCE, and PRACTICE.

-----we've just concluded the first part of Trigonometry ☺

Optional Extra Practice: Textbook Chapter 7.6 pg. 412, # 5, 7, 9-13, 16, 17

## Lesson 3.5 Sine Law (Super useful when it is NOT a Right Triangle!!)

For the Sine Law we need: - An angle and its opposite side, and one other piece of information.

The Sine Law:

$$\frac{a}{\sin A} = \frac{b}{\sin B} = \frac{c}{\sin C} \text{ or } \frac{\sin A}{a} = \frac{\sin B}{b} = \frac{\sin C}{c}$$

where  $a$  is the side opposite  $\angle A$ ,  $b$  is the side opposite  $\angle B$ , and  $c$  is the side opposite  $\angle C$

If we are trying to **find an angle**, use the first form of the Sine Law (**angles on top**)

If we are trying to **find the length** of a side, use the second form of the law (**with sides on top**)

Ex 1. Calculate

$$a = \left(\frac{3}{\sin 60}\right) \sin 72$$

Ex 2. Calculate:

$$\sin A = \left(\frac{\sin 72}{15}\right) 12$$

Ex. 3 – Solve for the given variable (correct to 1 decimal place) in each of the following:

(a)  $\frac{a}{\sin 55^\circ} = \frac{12}{\sin 30^\circ}$

(b)  $\frac{35}{\sin 65^\circ} = \frac{b}{\sin 38^\circ}$

Ex 4 - Find the Length of Side b to the nearest tenth

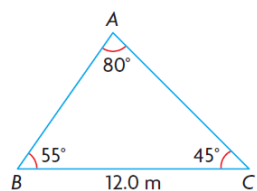

Ex. 5 – Find  $\angle S$  to the nearest degree.

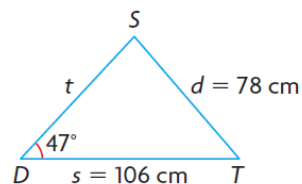

A telephone pole is supported by two wires on opposite sides. At the top of the pole, the wires form an angle of  $60^\circ$ . On the ground, the ends of the wires are  $15.0\text{ m}$  apart. One wire makes a  $45^\circ$  angle with the ground. How long are the wires, and how tall is the pole?

# Lesson 3.6 Cosine Law

Which Law do I Use?

Do I have a right angle triangle?

YES - use SOH CAH TOA

NO  
↓

Do I have a CORRESPONDING angle and side pair in the triangle?

YES - use SINE LAW

NO  
↓

Cannot use SOHCAHTOA or SINE Law      Must use the **The COSINE LAW**

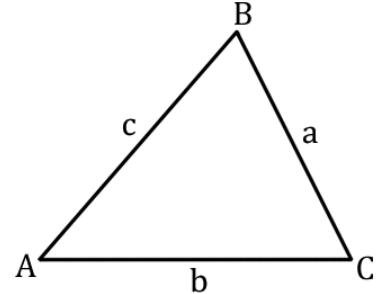

For the Cosine Law we need: - 2 sides and the included angle.  
- 3 sides

The cosine law is an extension of the Pythagorean theorem to triangles with no right angle.

**To find a side (have SAS):**

$$a^2 = b^2 + c^2 - 2bccosA$$

$$b^2 = a^2 + c^2 - 2accosB$$

$$c^2 = a^2 + b^2 - 2abcosC$$

**To find an angle (have SSS):**

$$cosA = \frac{a^2 - b^2 - c^2}{-2bc}$$

$$cosB = \frac{b^2 - a^2 - c^2}{-2ac}$$

$$cosC = \frac{c^2 - a^2 - b^2}{-2ab}$$

Ex 1. Calculate a if

$$a^2 = 4^2 + 6^2 - 2(4)(6)cos56$$

Ex 2. Calculate  $\angle X$  if:

$$cosX = \frac{4.5^2 - 3.2^2 - 4.6^2}{-2(3.2)(4.6)}$$

Determine if you need to use the SINE law or the COSINE law for the following triangles:

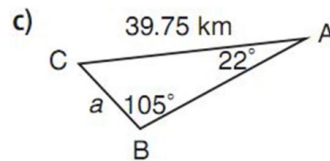
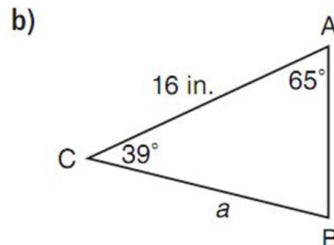
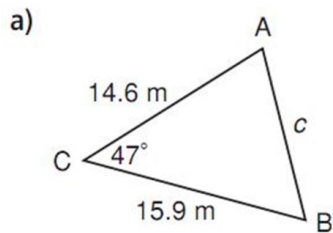

Draw the triangle and then find  $\angle A$  to the nearest tenth if  $a = 3\text{m}$ ,  $b = 5\text{m}$ , and  $c = 4.7\text{m}$

Draw the triangle then find side  $b$ , to the nearest tenth if  $\angle B = 68^\circ$ ,  $a = 17\text{ cm}$ , and  $c = 22\text{ cm}$

Ex. 5 The bases in a baseball diamond are 90 ft apart. A player picks up a ground ball 11 ft from third base, along the line from second base to third base. Determine the angle that is formed between first base, the player's present position, and home plate.

